

# Specimen Collection, Packaging and Shipping

Arizona State Public Health Laboratory

William Slanta  
Arizona Department of Health Services  
Bureau of State Laboratory Services

*Leadership for a Healthy Arizona*



# Specimen

## Specimen sources

- » Respiratory
- » Non-respiratory

## Specimen Quality

- » Factors:
  - Collection
  - Storage
  - Transportation
  - Labeling

# Specimen Collection

- Quality specimens are vital for lab diagnosis of TB
- Sputum: (expectorated or induced)
  - Collect 3 sputum specimens 8-24 hours apart
- Collect prior to therapy if possible
- No swabs, fixatives, preservatives

# Specimen Collection

- Thick and mucopurulent
- Desired minimal volume = 3mL (5-10mL preferred)
- Three early morning collected in sterile containers on consecutive days
- Do not pool specimens

# Specimen Collection

- Specimen collection containers requirements
  - Sterile
  - Leak-proof
  - Disposable
  - Non-breakable
  - Appropriately labeled!!!
- Laboratory Submission Form
  - <http://www.azdhs.gov/lab/micro/pdf/micro-submission-form.pdf>

# Laboratory Submission Form



## Bureau of Laboratory Services

250 N. 17<sup>th</sup> Avenue Phoenix, Arizona 85007-3231

Tel: (602) 542-1188 Fax: (602) 364-0758

Victor Waddell, Ph.D., Bureau Chief

For Department Use Only

### PATIENT INFORMATION

Last name: \_\_\_\_\_ First name: \_\_\_\_\_ MI: \_\_\_\_\_  
DOB (MM/DD/YYYY): \_\_\_\_\_ Age: \_\_\_\_\_ Sex:  M  F  T Patient ID: \_\_\_\_\_  
Street address: \_\_\_\_\_ City: \_\_\_\_\_ State: \_\_\_\_\_ Zip: \_\_\_\_\_ County: select one  
Ethnicity: Hispanic  Yes  No Race:  White  African American  Asian  American Indian/Alaska Native  Other

### SUBMITTING AGENCY INFORMATION

Agency name: \_\_\_\_\_ Agency ID Code: \_\_\_\_\_  
Street address: \_\_\_\_\_ City: \_\_\_\_\_ State: \_\_\_\_\_ Zip: \_\_\_\_\_ County: select one  
Contact name: \_\_\_\_\_ Tel: \_\_\_\_\_

### ORDERING PROVIDER INFORMATION

Provider name: \_\_\_\_\_ Tel: \_\_\_\_\_  
Facility name: \_\_\_\_\_ Tel: \_\_\_\_\_  
Street address: \_\_\_\_\_ City: \_\_\_\_\_ State: \_\_\_\_\_ Zip: \_\_\_\_\_ County: select one

### SPECIMEN INFORMATION & TYPE

Collection date: \_\_\_\_\_

<input type="checkbox"/> Serum <input type="checkbox"/> Acute <input type="checkbox"/> Convalescent	<input type="checkbox"/> Plasma	<input type="checkbox"/> Whole blood	<input type="checkbox"/> CSF
<input type="checkbox"/> Swab, site: _____	<input type="checkbox"/> Urine	<input type="checkbox"/> Sputum	<input type="checkbox"/> Stool
Other, specify: _____	<input type="checkbox"/> Tissue, specify: _____	<input type="checkbox"/> Wound, site: _____	<input type="checkbox"/> Body fluid, specify: _____

Clinical  Reference:  Broth  Isolate Reason for testing:  Outbreak  Surveillance  Post Mortem  Screening  Diagnostics

Outbreak name: \_\_\_\_\_

# AFB Specimen Transport

- Transport in as short as a time as possible to avoid overgrowth of contaminating bacteria
- Specimens that cannot be transported to the lab immediately should be refrigerated
- Reference the Guide to Laboratory Services
  - <http://www.azdhs.gov/lab/micro/index.htm>
- CDC recommendation:
  - Specimen received at laboratory within 24 hours of specimen collection.

# Transport of Biological Substances (Category B)

- Triple Package
  - primary receptacle
  - secondary packaging
  - rigid outer packaging
- Marking Requirements
  - Clearly marked "Biological Substance, Category B"
  - Marked with identification number "UN3373" in a square-on-point configuration
  - Name, address, and telephone number of a knowledgeable person



# Category B Packaging

## Acceptable Primary Receptacles

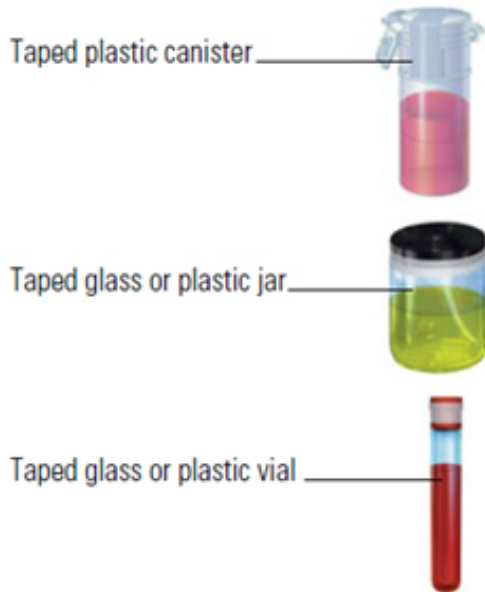

## Acceptable Secondary Receptacles



## Acceptable Absorbent Materials

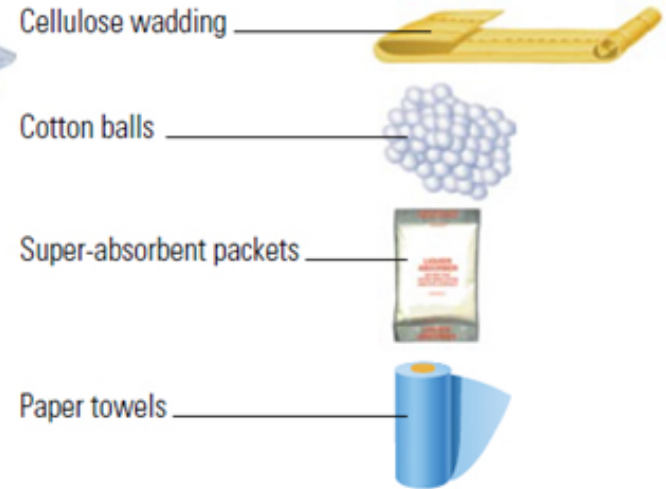

# Category B Packaging

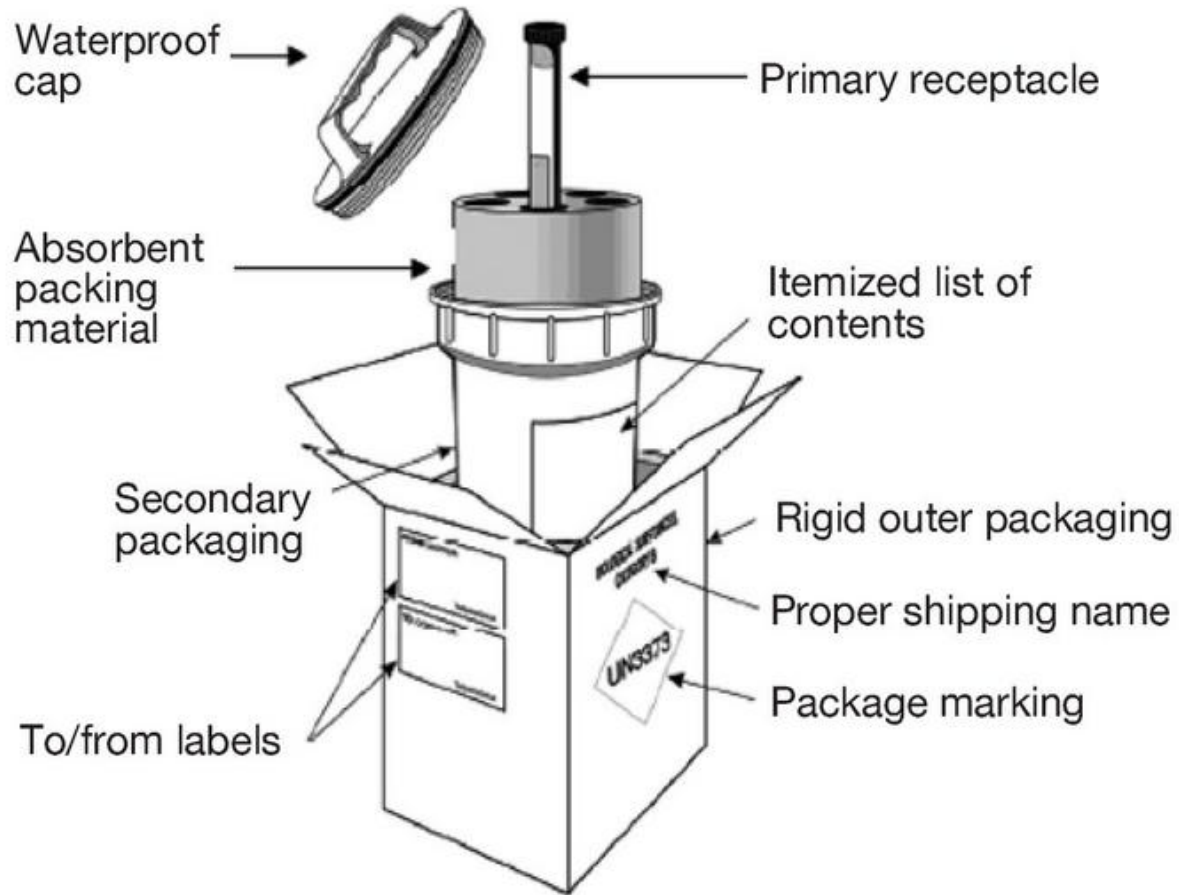

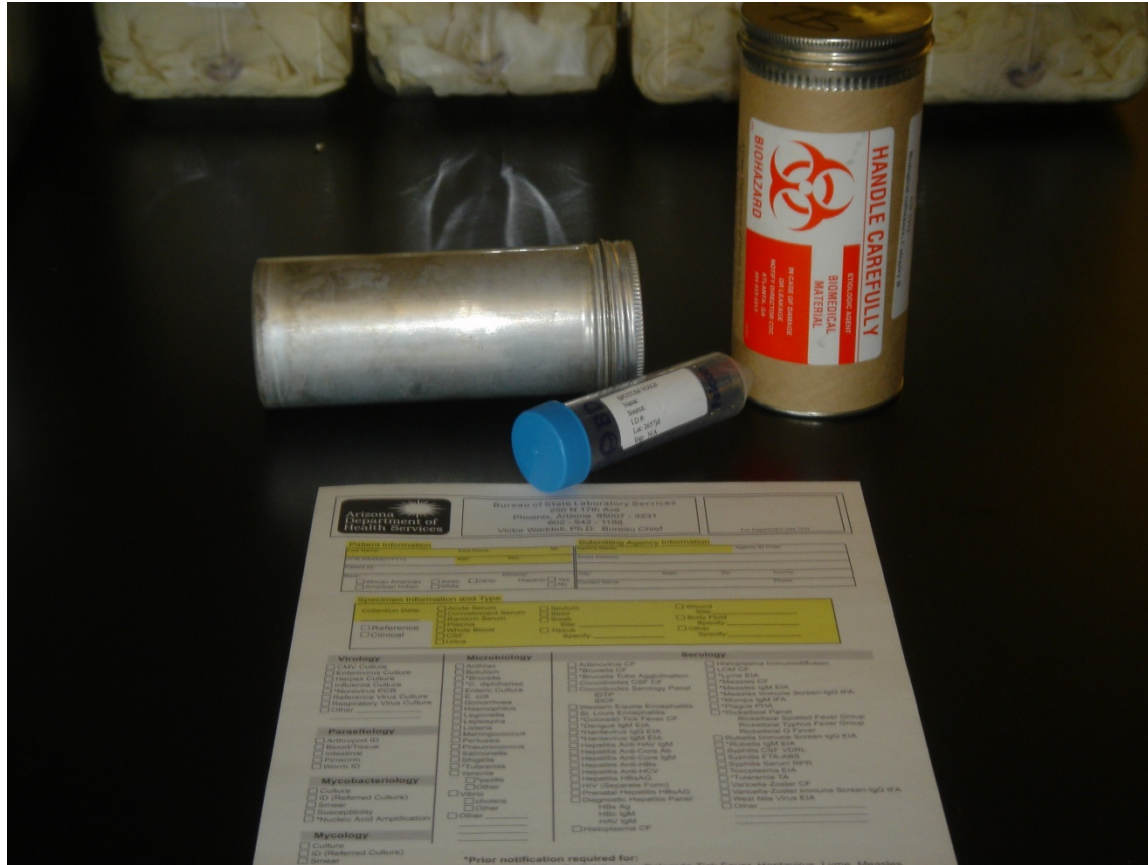

**Example of Collection Kit Supplied by ASL**  
 Inner metal screw capped container, outer screw capped cardboard container, place submission form around the outside of the inner metal container. **Label the specimen collection container with patient name and collection date.**

# Resources

- Guidelines for Submission of Sputum Specimens for TB testing
  - Developed by the APHL TB Steering Committee in April 2010
  - <http://www.aphl.org/aphlprograms/infectious/tuberculosis/TB-Core-Curriculum/Documents/SputumCollectionGuidelines.pdf>
- TB Core Curriculum: Essentials for the Mycobacteriology Laboratory
  - <http://www.aphl.org/aphlprograms/infectious/tuberculosis/tb-core-curriculum/Pages/default.aspx>

# Courier Services

## Significant Dates

- May 2006 Budget Package for courier through state general funds
- Dec 2010 L-SIP Recommendation for courier services from lab community
- June 2013 ADOA shuttle services for pickup and deliveries - Rejection
- Nov 16, 2013 Milwaukee Journal Sentinel Article

# Contractual Issues

- Does your state have courier/messenger services already on contract
- Is the contract specified for both messenger service (process service) and infectious substances

# Identify Service Needs

- Transport clinical and environmental specimens
- Routine pickups daily for statewide locations
- Same day deliveries – Phx and Tuc
- Overnight deliveries – other locations
- Deliveries to ASL during normal work hours 8 am – 5 pm

# Identify Service Needs

- Charges by location (pickup) rather than by #package(s), size, weight
- Packages to include Cat A and Cat B
- Knowledgeable of DOT regulations for shipping of infectious substances
- Secure temperature-controlled holding areas for packages not delivered same day



# Identify Locations

- Hospitals, clinical laboratories, local health departments
- Determine sample submission volume
  - Routine daily pick-ups / 40 locations
  - Will-call pickups / 41 locations

# Review and Award Contract



ez messenger

Prompt, Proficient, Reliable and Sustainable



*Leadership for a Healthy Arizona*



# To-do Tasks

## Courier

- Provide Logo
- Provide will-call phone and email contact
- Provide primary point of contact /questions
- Provide labeled receptacle for sample storage at pickup location
- Conduct dry runs prior to service to establish routes and introduce to clients

# To-do Tasks

## AZ State Lab

- Notify submitters to service availability
- Provide logo of ADHS and courier
- Establish sites as routine or will-call and notify clients
- Request information for pickup locations
- Establish start date for service

# Accountability

- Invoice generation
- Monthly logs
- Daily manifests

# Follow-up

- Location designation – clean up sites and designations
  - Addition or deletion of sites
  - Changes in routine vs. will-call